

THESE DESIGN/ENGINEERING DRAWING(S) ARE THE PROPERTY OF EMERGENCY VEHICLES, INC. THEY ARE PROPRIETARY, AND ARE FOR THE EXCLUSIVE USE OF YOUR ENTITY. ANY DIVULGING OF THIS DATA TO A THIRD PARTY IS PROHIBITED.

*[Signature]* DATE: 03/21/05

REVISION 1	03/24/05
REVISION 2	GR - 06/20/05
REVISION 3	NS - 12/22/05
REVISION 4	-
REVISION 5	-

Curbside Overall

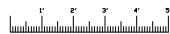

*EMERGENCY VEHICLES, INC.*

*Town of Davie Fire Rescue Dept.  
Davie, Florida*

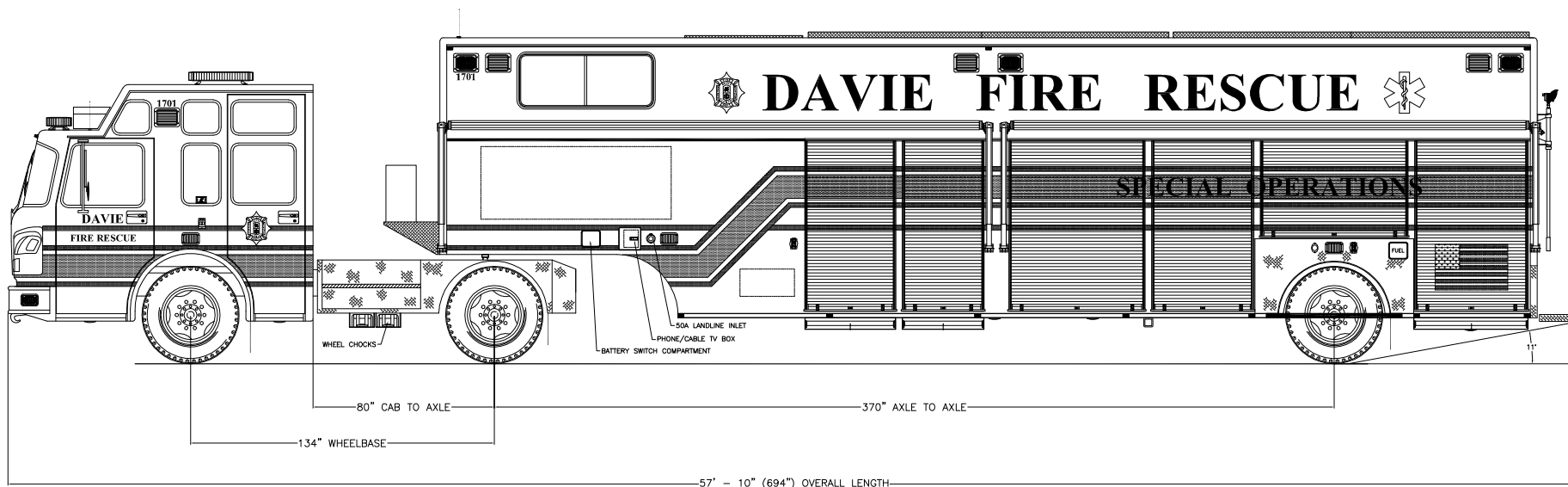

THESE DESIGN/ENGINEERING DRAWING(S) ARE THE PROPERTY OF EMERGENCY VEHICLES, INC. THEY ARE PROPRIETARY, AND ARE FOR THE EXCLUSIVE USE OF YOUR ENTITY. ANY DIVULGING OF THIS DATA TO A THIRD PARTY IS PROHIBITED.

*[Signature]* DATE: 03/21/05

REVISION 1	03/24/05
REVISION 2	GR - 06/20/05
REVISION 3	NS - 12/22/05
REVISION 4	-
REVISION 5	-

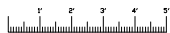

*Streetside Overall*

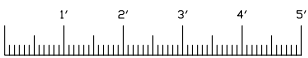
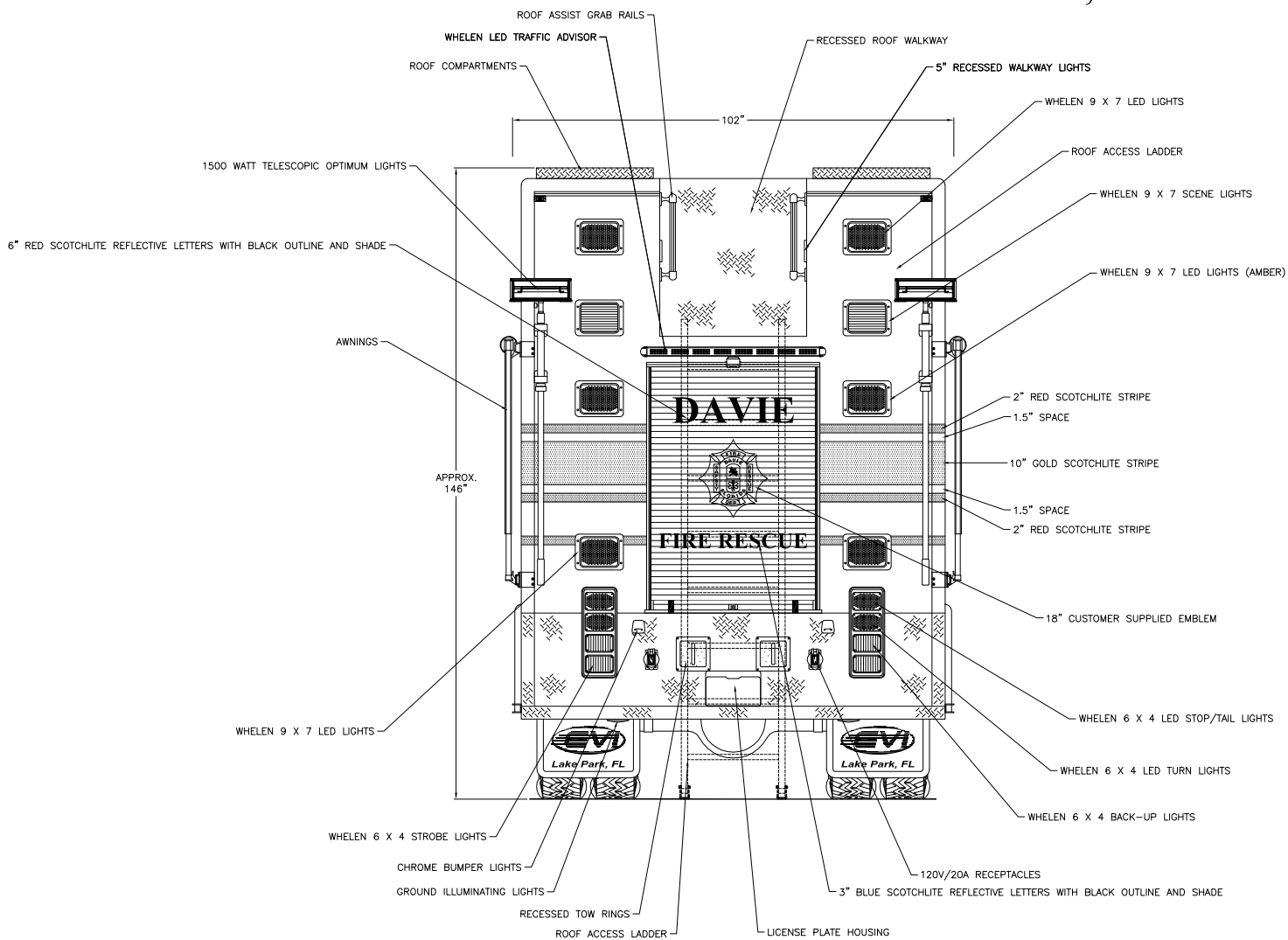

*Rear View*

THESE DESIGN/ENGINEERING DRAWING(S) ARE THE PROPERTY OF EMERGENCY VEHICLES, INC. THEY ARE PROPRIETARY, AND ARE FOR THE EXCLUSIVE USE OF YOUR ENTITY. ANY DIVULGING OF THIS DATA TO A THIRD PARTY IS PROHIBITED.

*[Signature]* DATE: 03/21/05

REVISION 1	03/24/05
REVISION 2	GR - 06/20/05
REVISION 3	NS - 12/22/05
REVISION 4	-
REVISION 5	-

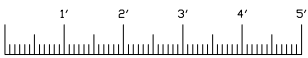

*Front Wall*

THESE DESIGN/ENGINEERING DRAWING(S) ARE THE PROPERTY OF EMERGENCY VEHICLES, INC. THEY ARE PROPRIETARY, AND ARE FOR THE EXCLUSIVE USE OF YOUR ENTITY. ANY DIVULGING OF THIS DATA TO A THIRD PARTY IS PROHIBITED.

\_\_\_\_\_  
DATE: 12/22/05

REVISION 1	-
REVISION 2	-
REVISION 3	-
REVISION 4	-
REVISION 5	-

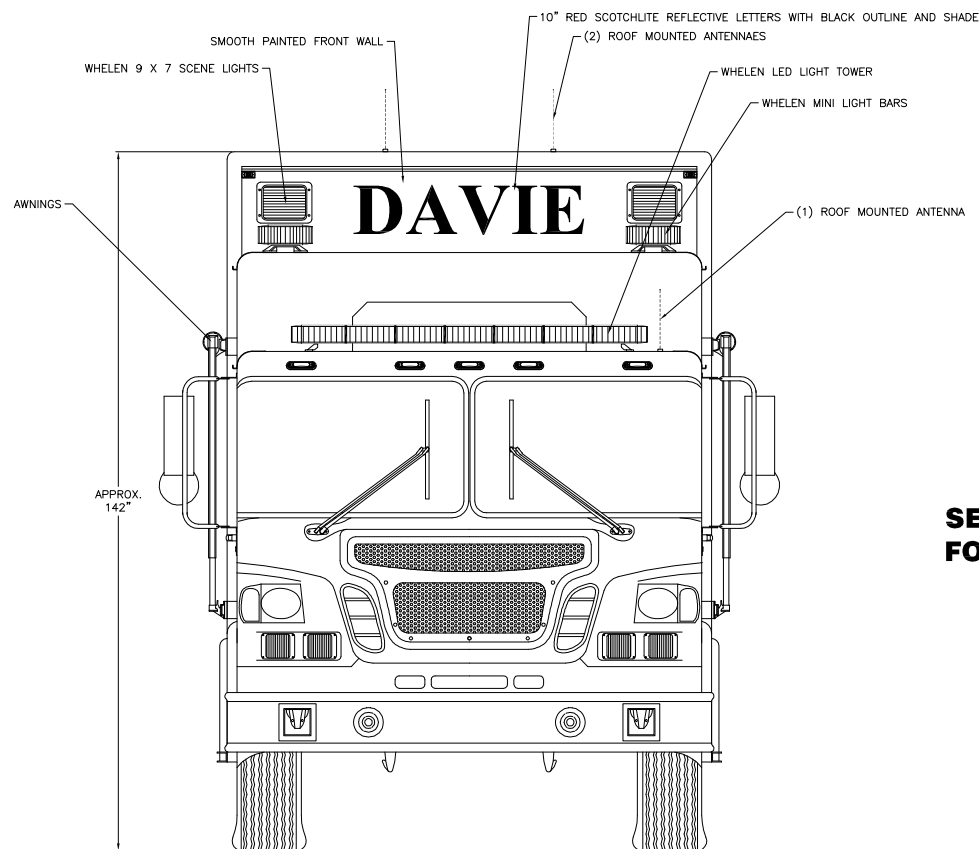

**SEE 'FRONT WALL' DRAWING  
FOR ADDITIONAL LETTERING**



*Front View*

THESE DESIGN/ENGINEERING DRAWING(S) ARE THE PROPERTY OF EMERGENCY VEHICLES, INC. THEY ARE PROPRIETARY, AND ARE FOR THE EXCLUSIVE USE OF YOUR ENTITY. ANY DIVULGING OF THIS DATA TO A THIRD PARTY IS PROHIBITED.

		DATE: 03/21/05
REVISION 1		03/24/05
REVISION 2	GR	06/20/05
REVISION 3	NS	12/22/05
REVISION 4	-	-
REVISION 5	-	-