

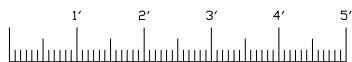

EMERGENCY VEHICLES, INC.

University of CT Health Center
Farmington, Connecticut

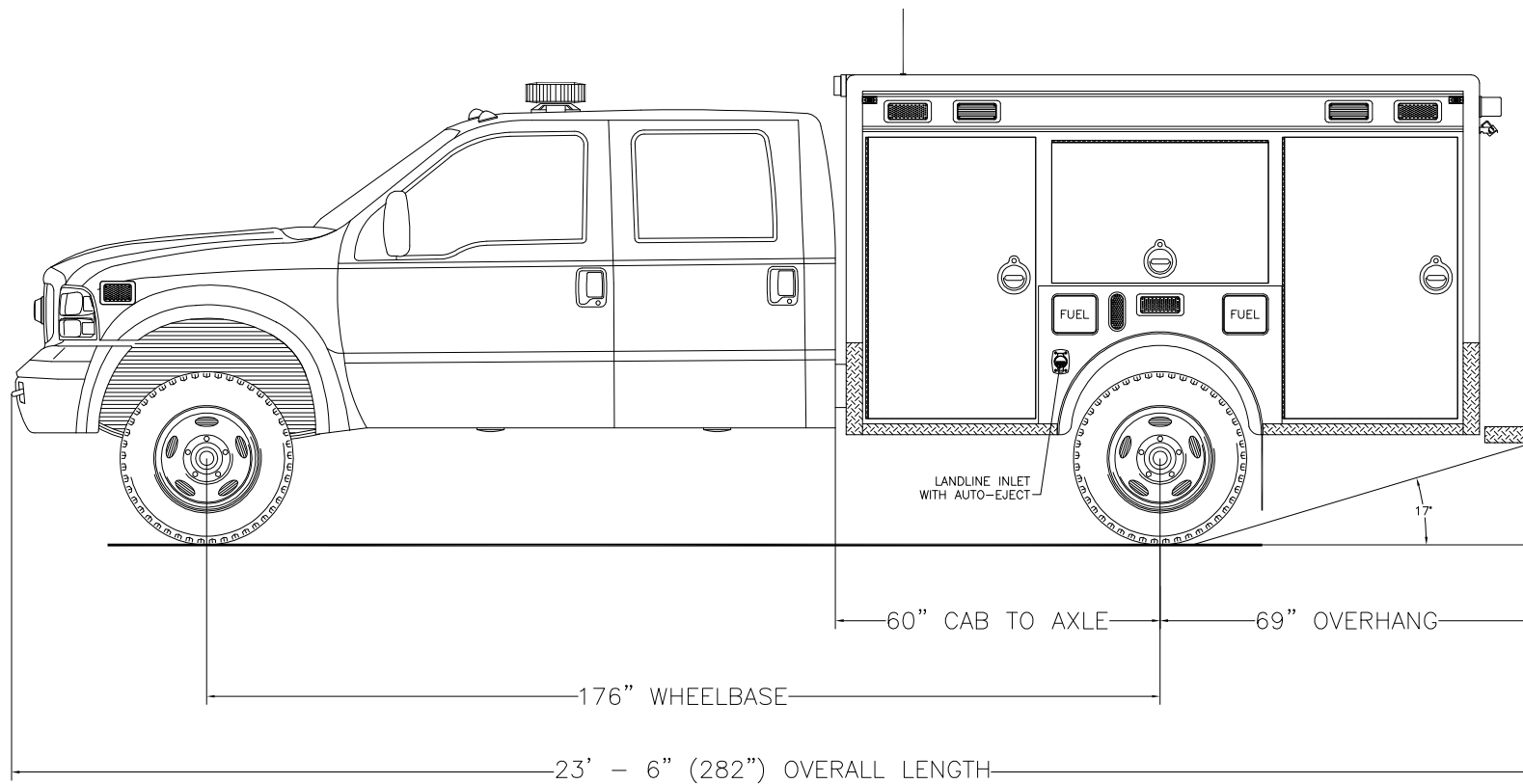

Streetside Overall

THESE DESIGN/ENGINEERING DRAWING(S) ARE THE PROPERTY OF EMERGENCY VEHICLES, INC. THEY ARE PROPRIETARY, AND ARE FOR THE EXCLUSIVE USE OF YOUR ENTITY. ANY DIVULGING OF THIS DATA TO A THIRD PARTY IS PROHIBITED.

		DATE: 03/07/07
REVISION 1	NS - 06/13/07	
REVISION 2	NS - 08/03/07	
REVISION 3	NS - 11/21/07	
REVISION 4	-	
REVISION 5	-	

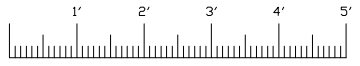
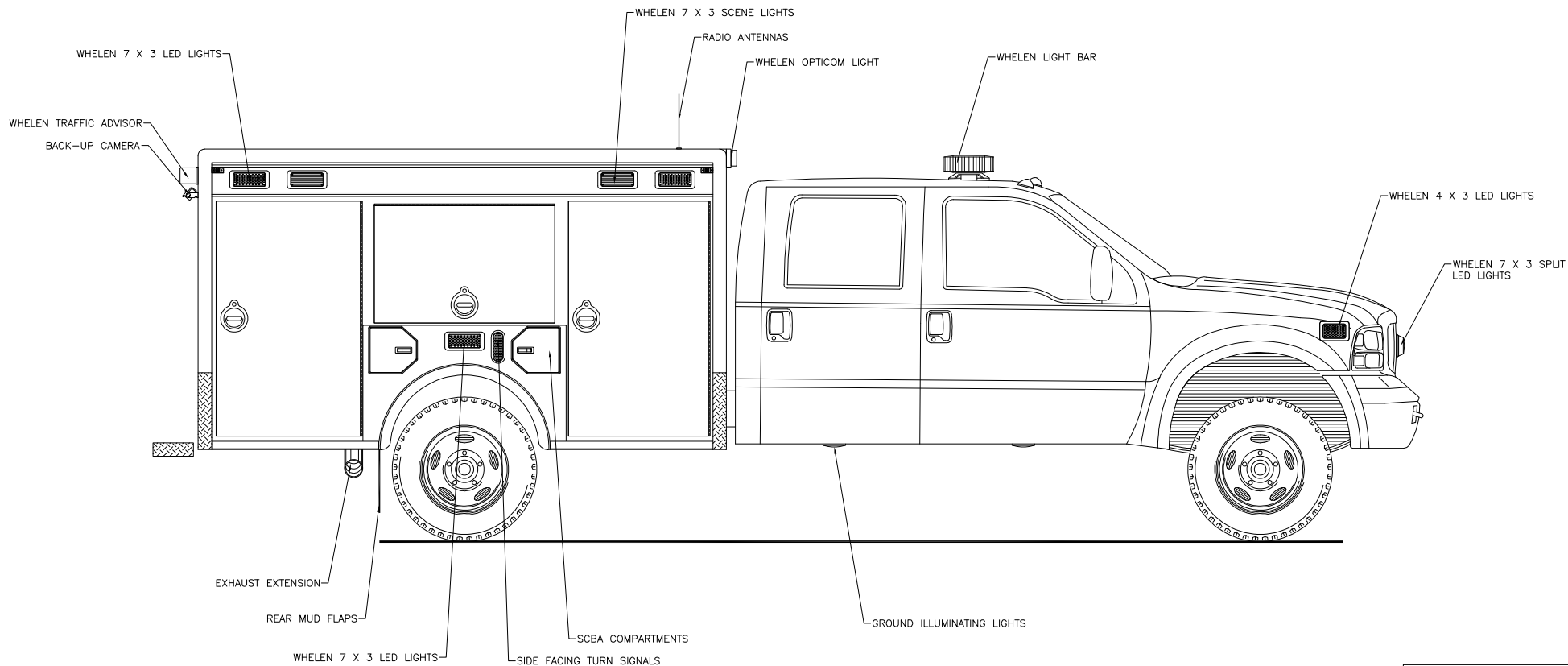

Curbside Overall

THESE DESIGN/ENGINEERING DRAWING(S) ARE THE PROPERTY OF EMERGENCY VEHICLES, INC. THEY ARE PROPRIETARY, AND ARE FOR THE EXCLUSIVE USE OF YOUR ENTITY. ANY DIVULGING OF THIS DATA TO A THIRD PARTY IS PROHIBITED.

E.V. [Signature] DATE: 03/07/07

REVISION 1	NS - 06/13/07
REVISION 2	NS - 08/03/07
REVISION 3	-
REVISION 4	-
REVISION 5	-

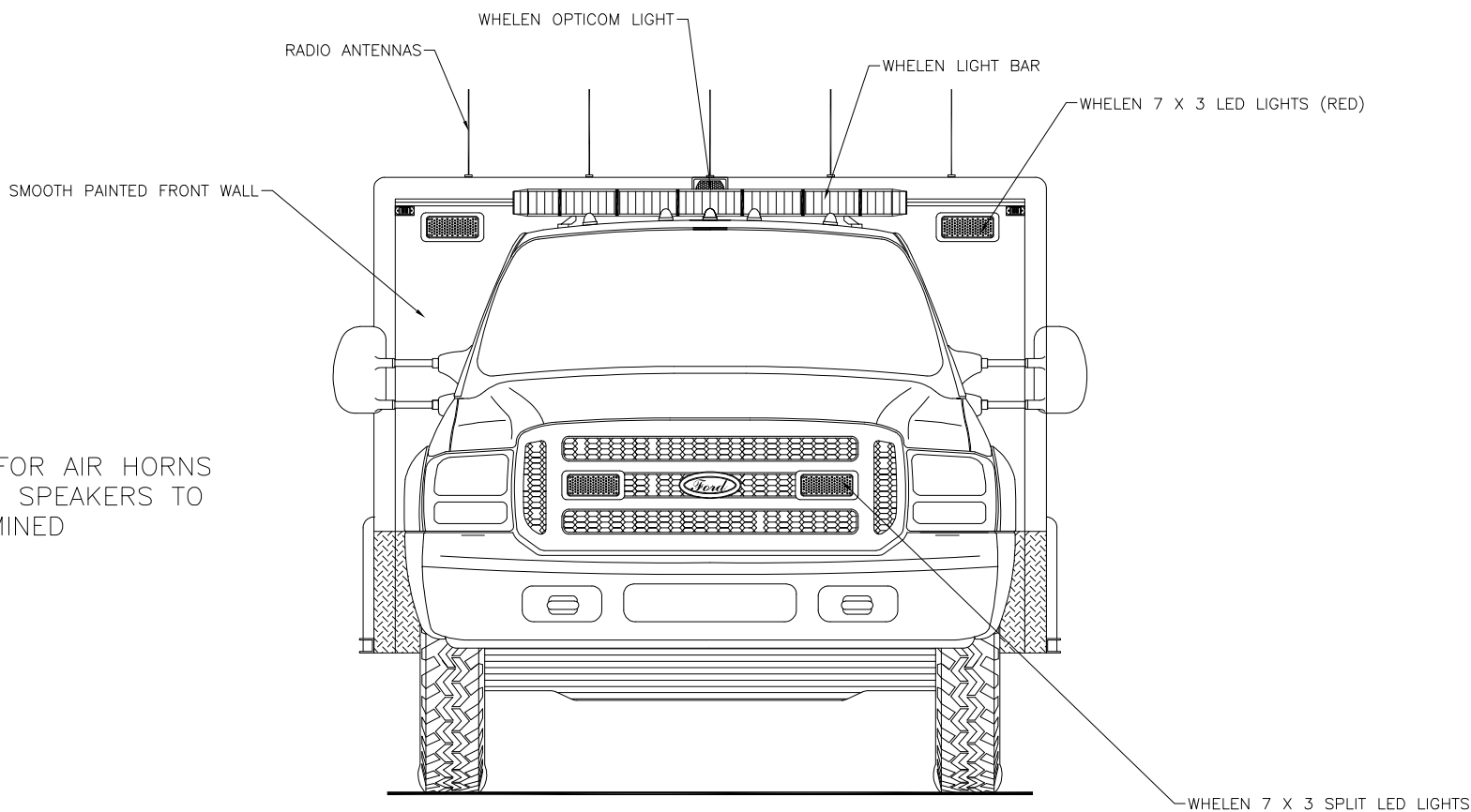

NOTE:
LOCATION FOR AIR HORNS
AND SIREN SPEAKERS TO
BE DETERMINED

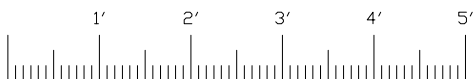

Front View

THESE DESIGN/ENGINEERING DRAWING(S) ARE THE PROPERTY OF EMERGENCY VEHICLES, INC. THEY ARE PROPRIETARY, AND ARE FOR THE EXCLUSIVE USE OF YOUR ENTITY. ANY DIVULGING OF THIS DATA TO A THIRD PARTY IS PROHIBITED.

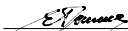
		DATE: 03/07/07
REVISION 1	NS - 06/13/07	
REVISION 2	NS - 08/03/07	
REVISION 3	-	
REVISION 4	-	
REVISION 5	-	

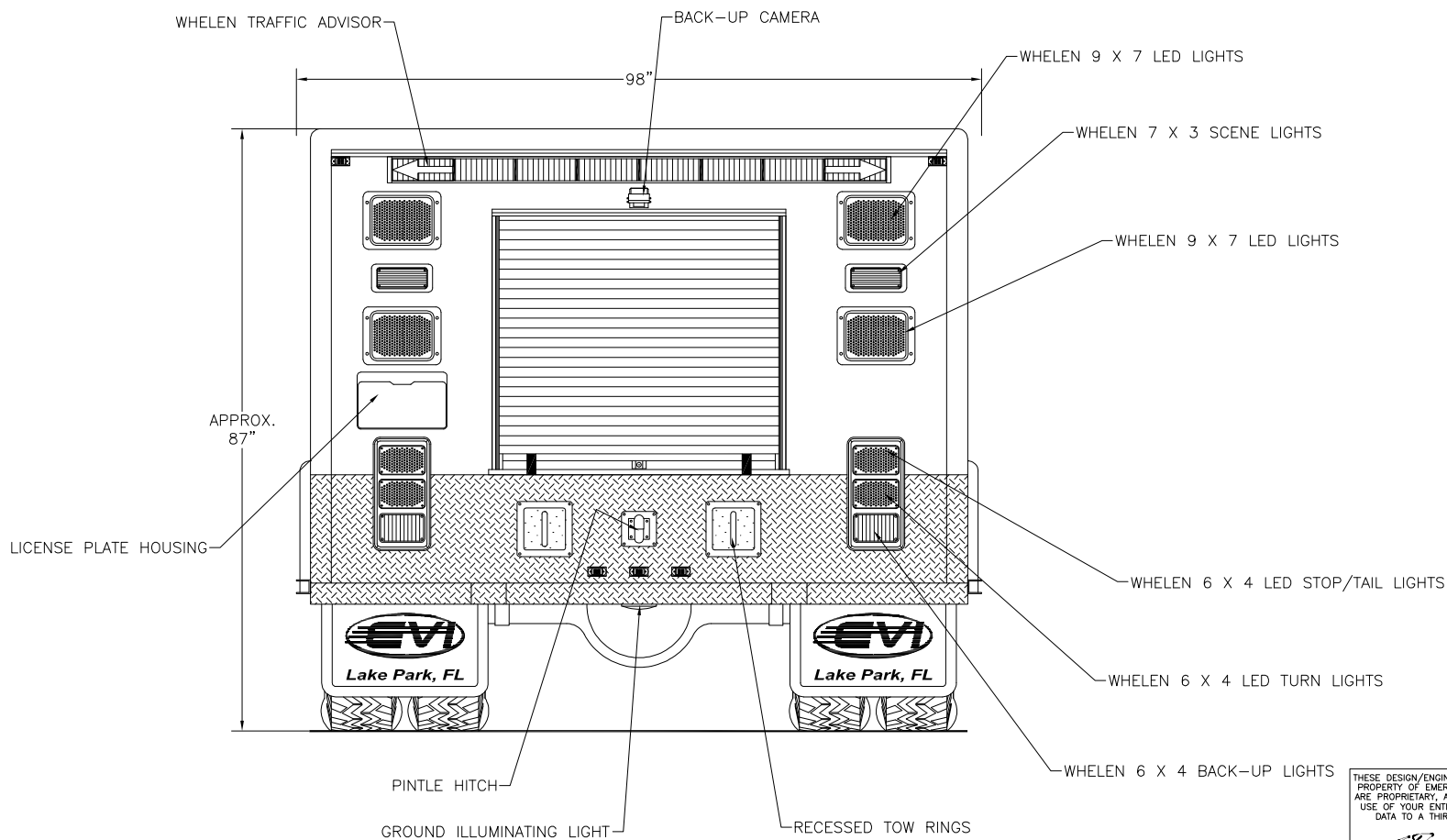

Rear View

THESE DESIGN/ENGINEERING DRAWING(S) ARE THE PROPERTY OF EMERGENCY VEHICLES, INC. THEY ARE PROPRIETARY, AND ARE FOR THE EXCLUSIVE USE OF YOUR ENTITY. ANY DIVULGING OF THIS DATA TO A THIRD PARTY IS PROHIBITED.

E.V. Penner DATE: 03/07/07

REVISION 1	NS - 06/13/07
REVISION 2	NS - 08/03/07
REVISION 3	-
REVISION 4	-
REVISION 5	-